

# JT8565

# SUBMINIATURE HIGH POWER RELAY



## Features

- 50A switching capability
- 1 Form B configuration available
- 250" quick connect termination
- Various of mounting positions
- Dust protected type available
- Outline Dimensions:(51.2 x 46.6 x 36.5)mm

## CONTACT DATA

Contact arrangement	1B
Contact resistance	100mΩ max.(at 1A 24VDC)
Contact material	AgSnO <sub>2</sub> ,AgCdO
Contact rating (Res.load)	16A(on and off) 400VAC COSØ=0.7~0.8 35A(off only) 400VAC COSØ=0.7~0.8 50A(off only) 400VAC COSØ=0.7~0.8
Mechanical endurance	7.5 x 10 <sup>5</sup> ops
Electrical endurance	SPST-NC:5 x 10 <sup>5</sup> ops(16A, on and off 400VAC COSØ=0.7~0.8, at 25°C, 1s on 9s off) SPST-NC:2 x 10 <sup>5</sup> ops(35A, off only 400VAC COSØ=0.7~0.8, at 25°C, 1s on 9s off) SPST-NC:1 x 10 <sup>5</sup> ops(50A, off only 400VAC COSØ=0.7~0.8, at 25°C, 1s on 9s off)

**Notes:** The data shown above are initial values.

## CHARACTERISTICS

Unit weight	Approx. 110g
Termination	QC
Construction	Dust protected

## COIL

Coil power	Approx. 5VA
Coil voltage	See table below
Coil resistance	See table below
Insulation system	Class F

## OPERATING CHARACTERISTICS at 50Hz

Coil number	2		3		4		5		6		7		8		9		
Max vol.(V) at 40°C	299		338		378		356		452		151		530		228		
Coil resistance (1±10%)Ω at 25°C	5600		7500		10700		10000		13800		1500		19500		3900		
	H.P.U	P.U	D.O	P.U	D.O	P.U	D.O	P.U	D.O	P.U	D.O	P.U	D.O	P.U	D.O	P.U	D.O
A	120-130											111-124	20-45			111-124	35-77
B	130-140											120-134	20-45			120-134	35-77
C	150-160	140-153	40-90									130-144	20-45			130-144	35-77
D	160-170	150-163	40-90	150-163	40-90							140-153	20-45			140-153	35-77
E	170-180	162-175	40-90	162-175	40-90											149-163	35-77
F	180-190	171-184	40-90	171-184	40-90			180-195	40-105							159-172	35-77
G	190-200	180-193	40-90	180-195	40-105	180-195	40-105	189-205	40-105							168-182	35-77
H	200-220	186-215	40-90	190-215	40-105	195-224	50-110	186-214	60-133							178-192	35-77
I	220-240	205-234	40-105	208-239	50-110	204-233	50-110	204-233	60-133							183-213	35-77
L	240-260	224-252	40-105	224-252	50-110	223-259	50-110	223-252	60-133	223-252	60-130					203-231	35-77
M	260-280	243-271	40-105	239-270	50-110	242-272	50-110	242-272	60-133	239-268	60-135			239-268	75-170		
N	280-300			260-289	50-110	262-290	60-121	262-290	60-133	258-287	60-135			258-287	75-170		
O	300-320					280-310	60-121	280-310	60-133	277-305	60-135			277-305	75-170		
P	320-340					300-328	60-121	300-328	60-154	295-324	60-135			295-324	75-170		
Q	340-360					318-347	60-121			314-342	60-135			314-342	75-180		
R	350-370													323-352	75-180		
S	360-380													332-361	75-180		

**Note:**H.P.U.means Approximate pick-up value at 90°C, P.U.means Pick-up value at 25°C,D.O.means drop out value at 25°C.



JINTIAN RELAY

ISO9001、ISO14001、OHSAS18001 CERTIFIED

## OPERATING CHARACTERISTICS at 60Hz

Coil number	2		3		4		5		6		7		8		9		
Max vol.(V) at 40°C	332		375		420		395		502		168		588		253		
Coil number (1±10%)Ω at 25°C	5600		7500		10700		10000		13800		1500		19500		3900		
	H.P.U	P.U	D.O	P.U	D.O	P.U	D.O	P.U	D.O	P.U	D.O	P.U	D.O	P.U	D.O	P.U	D.O
AA	120-130											111-124	20-45			111-124	35-77
AB	130-140											120-134	20-45			120-134	35-77
AC	150-160											130-144	20-45			130-144	35-77
AD	160-170	150-163	40-90									140-153	20-45			140-153	35-77
AE	170-180	162-175	40-90									149-163	20-45			149-163	35-77
AF	180-190	171-184	40-90					180-195	40-105							157-172	35-77
AG	190-200	180-193	40-90	180-195	40-105			189-205	40-105							168-182	35-77
AH	200-220	186-215	40-90	190-215	40-105	195-224	60-121	186-214	60-130							178-192	35-77
AI	220-240	205-234	40-105	208-239	50-110	204-233	60-121	204-233	60-130							183-213	35-77
AL	240-260	224-252	40-105	224-252	50-110	223-259	60-121	223-252	60-130							203-231	35-77
AM	260-280	243-271	40-105	239-270	50-110	242-272	60-121	242-272	60-140	239-268	60-135					221-250	35-77
AN	280-300			260-289	50-110	262-290	60-121	262-290	60-140	258-287	60-135			258-287	75-170		
AO	300-320					280-310	60-121	280-310	60-140	277-305	60-135			277-305	75-170		
AP	320-340					300-328	60-121	300-328	60-140	295-324	60-135			295-324	75-170		
AQ	340-360					318-347	60-121			314-342	60-135			314-342	75-180		
AR	350-370													323-352	75-180		
AS	360-380													332-361	75-180		

Note:H.P.U.means Approximate pick-up value at 90°C, P.U.means Pick-up value at 25°C,D.O.means drop out value at 25°C.

## OPERATING POSITION

Unit: mm

	1	2	3	4	5	6
PLASTIC TAB MOUNT						
PANEL MOUNT						
METAL TAB MOUNT						

## OPERATING POSITION

Unit: mm

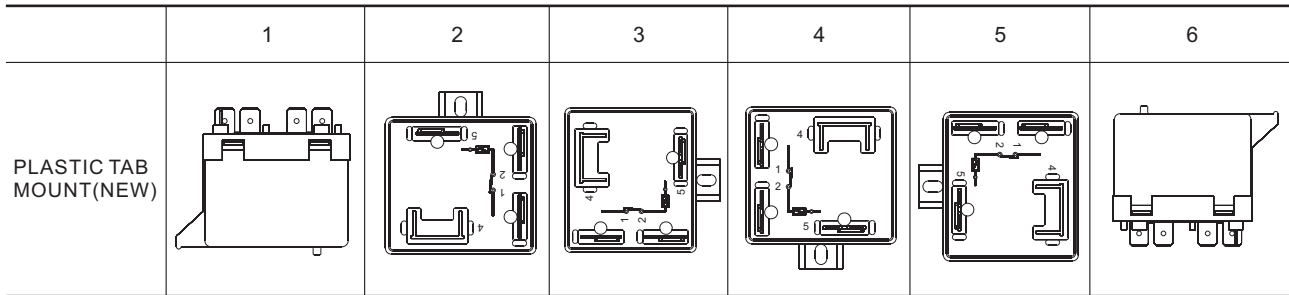

## TERMINAL CONFIGURATION

MOUNT METHOD	TYPE MARKING	TERMINATION
PLASTIC TAB MOUNT	B	5 dual QC, 1#, 2#, 4#, 5# (4# is blank U type terminal)
	D	3 dual QC(1#, 2#, 5#)
	K	3 dual QC(1#, 2#, 5#)
PANEL MOUNT	M	5 dual QC, 1#, 2#, 4#, 5# (4# is blank U type terminal)
	P	3 dual QC(1#, 2#, 5#)
METAL TAB MOUNT	U	5 dual QC, 1#, 2#, 4#, 5# (4# is blank U type terminal)
	X	5 dual QC, 1#, 2#, 4#, 5# (4# is blank U type terminal)
	Z	3 dual QC(1#, 2#, 5#)

## ORDERING INFORMATION

**JT8565 T/ D 6 A 1 (XXX)**

### Type

**Contact material**<sup>1)</sup> T:AgSnO<sub>2</sub> Nil:AgCdO

**Terminal configuration** B, D, K, M, P, X, Z

**Coil number** 2, 3, 4, 5, 6, 7, 8, 9

**Operation characteristics** AA to AS  
(See table for operating characteristics)

**Operation position** 1, 2, 3, 4, 5, 6

**Special code**<sup>2)</sup> **XXX**: Customer special requirement Nil: Standrad

**Notes:** 1) AgSnO<sub>2</sub> contact can be represented as "(T)" after periodic code.

2) The customer special requirement express as special code after evaluating by JINTIAN.

# OUTLINE DIMENSIONS, WIRING DIAGRAM AND PC BOARD LAYOUT

Unit: mm

Plastic Mab Mount

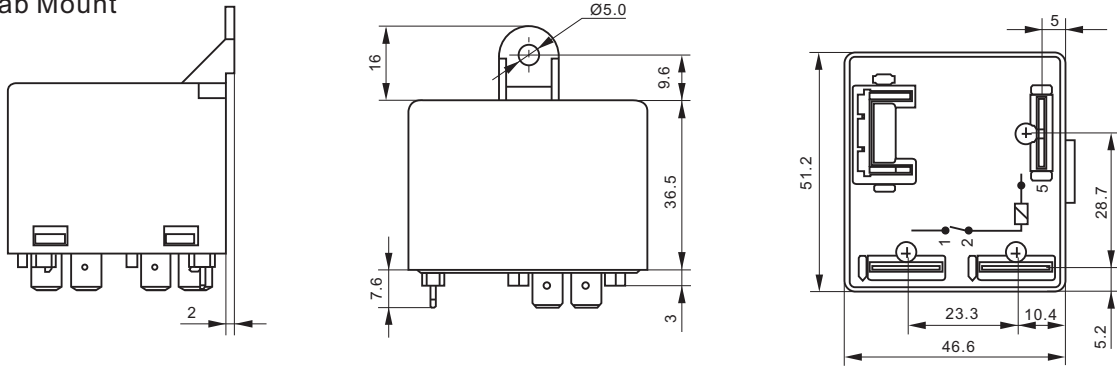

Panel Mount

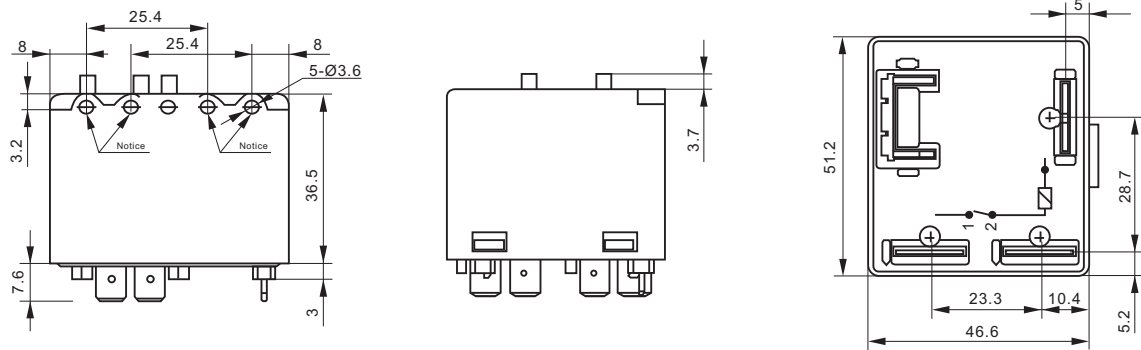

Metal Mount

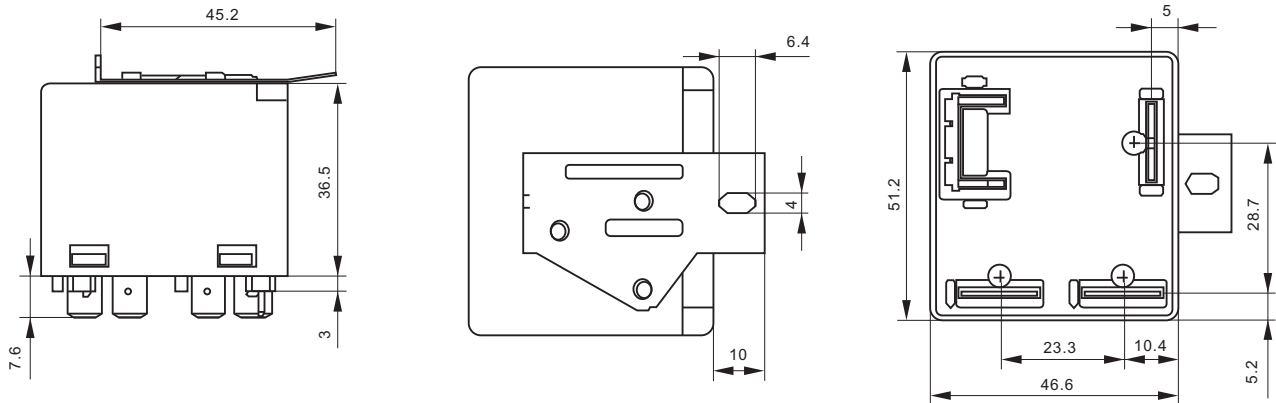

Plastic Mab Mount(New)

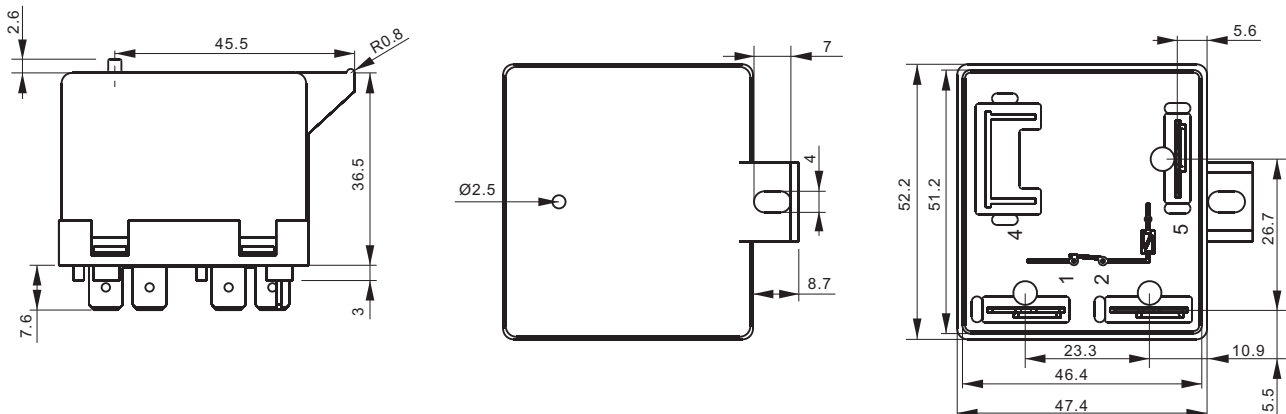

Remark: In case of no tolerance shown in outline dimension: outline dimension  $\leq 1$ mm, tolerance should be  $\pm 0.2$ mm; outline dimension  $> 1$ mm and  $\leq 5$ mm, tolerance should be  $\pm 0.3$ mm; outline dimension  $> 5$ mm, tolerance should be  $\pm 0.4$ mm.

Wiring Diagram

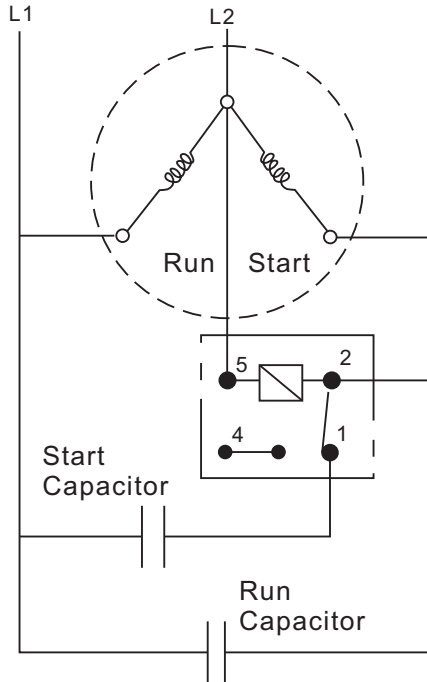

**Disclaimer**

The specification is for reference only. See to "Terminology and Guidelines" for more information. Specifications subject to change without notice. We could not evaluate all the performance and all the parameters for every possible application. Thus the user should be in a right position to choose the suitable product for their own application. If there is any query, please contact JINTIAN for the technical service. However, it is the user's responsibility to determine which product should be used only.